



WELDING TORCHES & CONSUMABLES



(+90) 444 93 53
magmaWeld.com
info@magmaWeld.com

 (+90) 538 927 12 62



CORPORATE

Magmaweld Magmaweld is a manufacturer of Stick Electrodes, MIG/MAG & TIG Wires, Flux Cored Wires, Submerged-Arc Wires and Fluxes, Welding Machines, Welding Ancillary Products and Automation Systems in Turkey. Oerlikon Kaynak Elektrodları ve Sanayi A.Ş. was founded in 1957 in order to manufacture stick electrodes as a licensee of Oerlikon-Buehrle AG.

In the year 1996, in order to reduce costs, to strengthen the leading position in Turkey and turn Magmaweld into a global brand, two old factories in Istanbul were moved to new, state of the art factory in Manisa, situated in the west of Turkey. In 2010 the second factory has been opened also in Manisa to produce high-tech welding equipment as well as to integrate robotic automation systems.

The MAGMAWELD brand came out as an analogy between the molten core of the earth, the MAGMA and the WELDPPOOL.

Magmaweld greatly values technical education and has been contributing to the training and education of thousands of welders through regular, free of charge courses since 1961. This service helps to increase consumer awareness and technical competence throughout the industry.

Magmaweld strives for customer satisfaction and process excellence. In order to satisfy customer needs, all questions and remarks about products, training, welding technologies, welding procedures, standards, work safety and automation are processed through the call center at +90 444WELD (4449353) or through live support from www.magmaweld.com where the relevant information is directed to Magmaweld's experts.



Welding Consumables Factory
Organize Sanayi Bölgesi 2. Kısım, Manisa, Turkey



Welding Machines and Automation Factory
Organize Sanayi Bölgesi 5. Kısım, Manisa, Turkey

CONTENTS

MIG TORCHES

Lava MIG Series	6
Lava MIG 15	8
Lava MIG 25	9
Lava MIG 35	10
Lava MIG 40	11
Lava MIG 50W	12
Lava MIG 65W	13

TIG TORCHES

Lava TIG Series	14
Lava TIG 9	16
Lava TIG 17	17
Lava TIG 26	18
Lava TIG 24	19
Lava TIG 20W	20
Lava TIG 18W	21

PLASMA TORCHES

Lava CUT Series	22
-----------------	----



CONSUMABLES AND ACCESSORIES

MIG Consumables	26
TIG Consumables	30
Tungsten Electrodes	33
Regulators and Heaters	33
Plasma Consumables	34



Lava MIG Series

Magmaweld MIG torches will meet with your requirements on Price / Performance ratios.

Consumables

Easy to find top quality and affordable consumables.

Hanger Function

With its standard hook feature, it provides ease of use by hanging the torch comfortably.

Ergonomic Trigger*

The robust and precise trigger mechanism is designed to be disassembled and serviced in seconds.



Connection Pins

Brass pins supported by an unbreakable spring. It provides highest conductivity and durability.

Back Connector and Ports

Case made of glass-reinforced polymer material and manufactured in accordance with EN 60974-1 standards. Connection points provides high strength and impermeability together with precision production technology.

Swan Neck

Specially designed swan neck with high thermal conductivity power.

Control Button*

With interchangeable 3/4 button options, remote control functions can be activated.

Grip Handle

Screwless, patented design combines balance, lightness and ergonomics. It offers a comfortable use to the welder with its upper and lower non-slip surfaces. It can be disassembled and served in seconds.



Cable Support

With pressed polymer material carries the strength to the next level.

Cable Assembly

Cable assembly with Duraflex material in air cooled models has high heat and abrasion resistance. Polymer support with cross-link structure offers resistance up to 3750C.

At water-cooled models, Hydroflex material used at outer sheath. It offers high strength and thermal insulation with flexible structure.

Cable/Hose Protection

At water-cooled models, the water inlet and outlet hoses are supported by polymer from the connector outlet and strength is increased.

Cable harness is suitable for heavy usage conditions with steel spring support.

*It varies according to the model.

MIG Torches

Lava MIG Series

Magmaweld MIG torches will meet with your requirements on Price / Performance ratios.



Technical Specifications		Lava MIG 15	Lava MIG 25	Lava MIG 35	Lava MIG 40	Lava MIG 50W/WR	Lava MIG 65W
Current	CO ₂	180 A	230 A	320 A	340 A	500 A / (WR) 500 A	550 A
Duty Cycle		%60	%60	%60	%60	%100	%100
Cooling Type		Air	Air	Air	Air	Water	Double Water
Product Codes	Torch 3 m	7120015003	7120020003	7120035003	7120040003	7120050003 / (WR) 7120150003	7120160003
	4 m	7120015004	7120020004	7120035004	7120040004	7120050004 / (WR) 7120150004	7120160004
	5 m	7120015005	7120020005	7120035005	7120040005	7120050005 / (WR) 7120150005	7120160005
	CO ₂ Regulator				7020001005		
	Argon/Mix Regulator				7020001004		
CO ₂ Heater 220V				7020009002			
CO ₂ Heater 24V				7020009003			

Air Cooled MIG Torch

Lava MIG 15

180A CO₂ 150A mix gas, EN60974-7 @ %60 Duty Cycle, 0,6 – 1.00 mm Wire Diameter

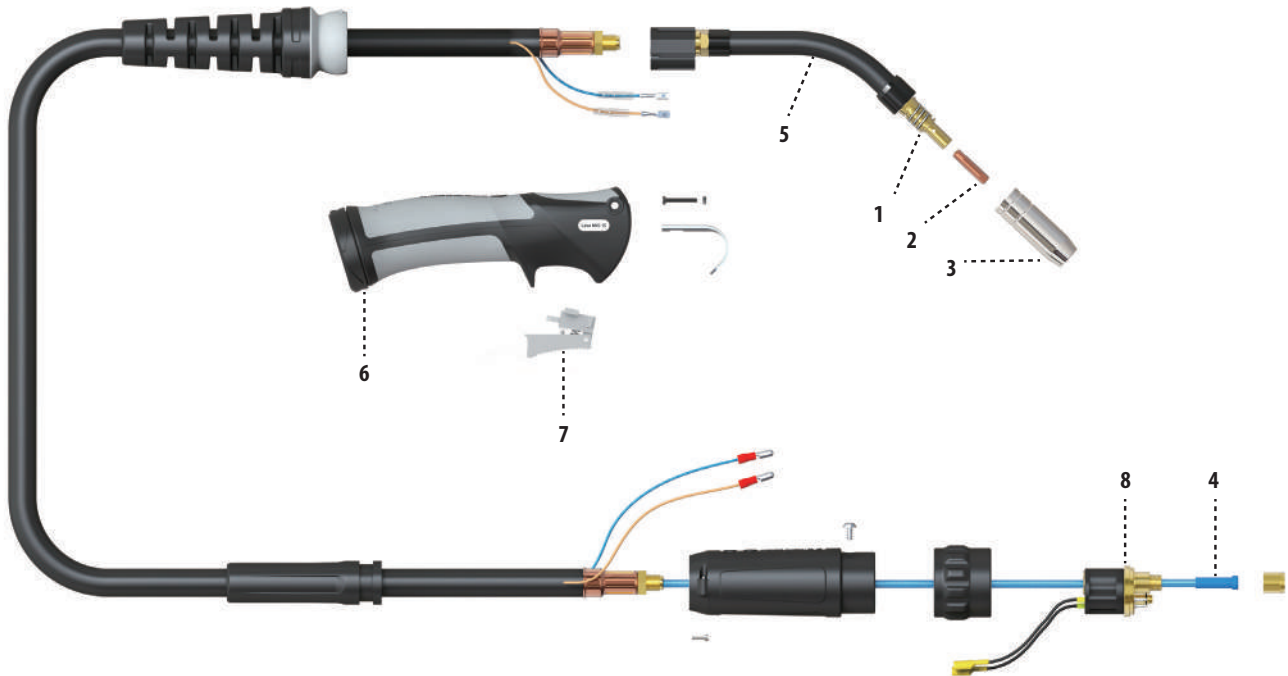

Model	Product Code		
	3 m	4 m	5 m
Lava MIG 15	7120015003	7120015004	7120015005

Consumables					
Part No.	Product Name	Product Code	Part No.	Product Name	Product Code
1	Tip Holder	7026000156	4	Teflon Liner	
2	Contact Tips			0.6 - 0.9 mm / 3 m	7025530610
	M6 x 0.6 x L25 mm	7023062506		0.6 - 0.9 mm / 4 m	7025540610
	M6 x 0.8 x L25 mm	7023062508		1.0 - 1.2 mm / 3 m	7025531012
	M6 x 1.0 x L25 mm	7023062510		1.0 - 1.2 mm / 4 m	7025541012
	M6 x 1.2 x L25 mm	7023062512		1.0 - 1.2 mm / 5 m	7025551012
3	Nozzle (Ø12 x 53 mm)	7022001253	5	Swan Neck	Y522000562
4	Steel Liner		6	Handle	Y522000559
	0.6 - 0.9 mm / 3 m	7025030609	7	Trigger Switch	Y522000560
	0.6 - 0.9 mm / 4 m	7025040609	8	Euro Connector	Y522000561
	0.6 - 0.9 mm / 5 m	7025050609			
	1.0 - 1.2 mm / 3 m	7025031012			
	1.0 - 1.2 mm / 4 m	7025041012			
	1.0 - 1.2 mm / 5 m	7025051012			

Air Cooled MIG Torch

Lava MIG 25

230A CO₂ 200A mix gas, EN60974-7 @ %60 Duty Cycle, 0,8 – 1.20 mm Wire Diameter

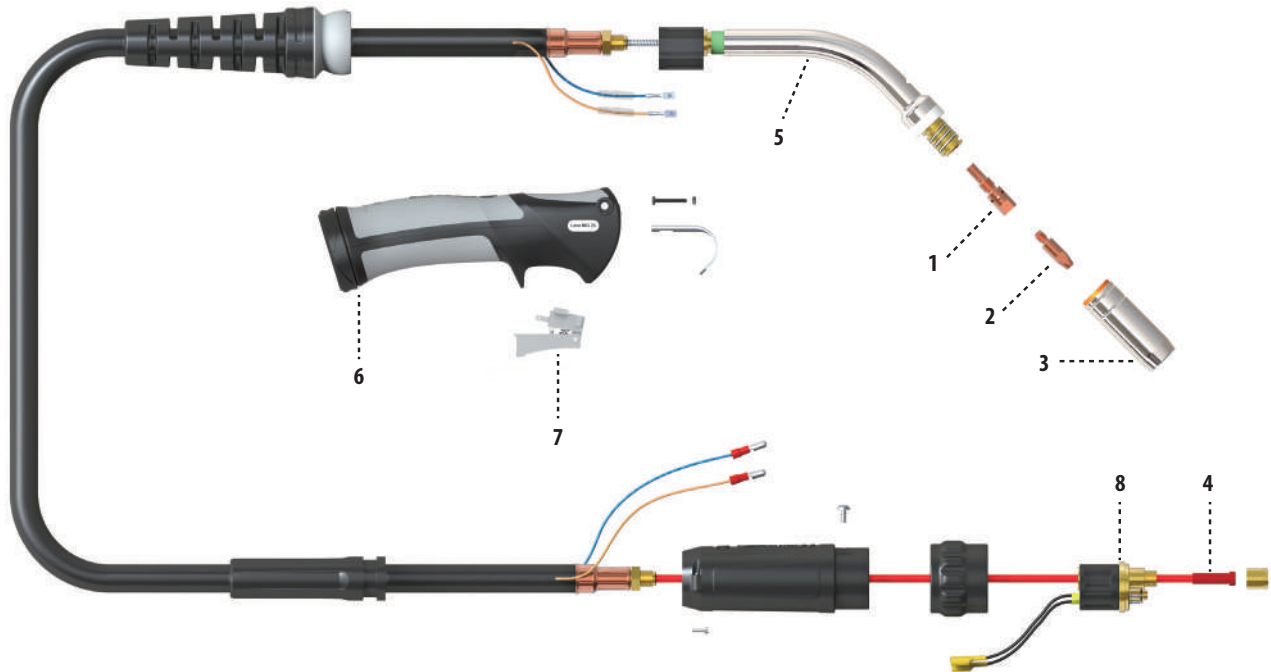

Model	Product Code		
	3 m	4 m	5 m
Lava MIG 25	7120020003	7120020004	7120020005

Consumables					
Part No.	Product Name	Product Code	Part No.	Product Name	Product Code
1	Tip Holder (M6)	7026000256	4	Teflon Liner	
2	Contact Tips			0.6 - 0.9 mm / 3 m	7025530610
	M6 x 0.6 x L28 mm	7023062806		0.6 - 0.9 mm / 4 m	7025540610
	M6 x 0.8 x L28 mm	7023062808		1.0 - 1.2 mm / 3 m	7025531012
	M6 x 1.0 x L28 mm	7023062810		1.0 - 1.2 mm / 4 m	7025541012
	M6 x 1.2 x L28 mm	7023062812		1.0 - 1.2 mm / 5 m	7025551012
3	Nozzle Narrow (Ø12 x 57.5 mm)	7022011253	5	Swan Neck	Y522000563
	Nozzle Conical (Ø15 x 57.5 mm)	7022001554	6	Handle	Y522000559
4	Steel Liner		7	Trigger Switch	Y522000560
	0.6 - 0.9 mm / 3 m	7025030609	8	Euro Connector	Y522000561
	0.6 - 0.9 mm / 4 m	7025040609			
	0.6 - 0.9 mm / 5 m	7025050609			
	1.0 - 1.2 mm / 3 m	7025031012			
	1.0 - 1.2 mm / 4 m	7025041012			
	1.0 - 1.2 mm / 5 m	7025051012			

Air Cooled MIG Torch

Lava MIG 35

320A CO₂ 290A mix gas, EN60974-7 @ %60 Duty Cycle, 0,8 – 1.20 mm Wire Diameter

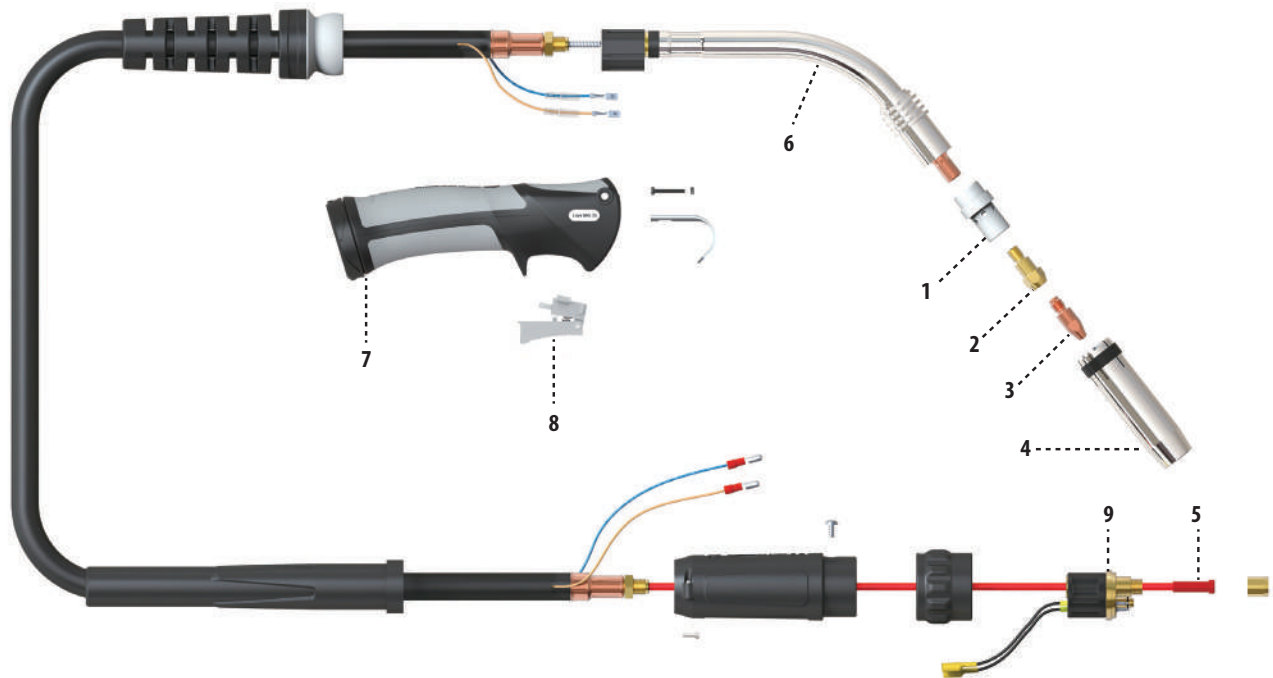

Model	Product Code		
	3 m	4 m	5 m
Lava MIG 35	7120035003	7120035004	7120035005

Consumables					
Part No.	Product Name	Product Code	Part No.	Product Name	Product Code
1	Gas Diffuser	7024100035	5	Steel Liner	
2	Tip Holder (M6) (Optional)	7026000356		1.2 - 1.6 mm / 4 m	7025041216
	Tip Holder (M8) (Standard)	7026000358		1.2 - 1.6 mm / 5 m	7025051216
3	Contact Tips			1.6 - 2.4 mm / 3 m	7025032024
	M6 x 0.6 x L28 mm	7023062806		1.6 - 2.4 mm / 4 m	7025042024
	M6 x 0.8 x L28 mm	7023062808		1.6 - 2.4 mm / 5 m	7025052024
	M6 x 1.0 x L28 mm	7023062810	5	Teflon Liner	
	M6 x 1.2 x L28 mm	7023062812		1.0 - 1.2 mm / 3 m	7025531012
	M8 x 0.8 x L30 mm	7023083008		1.0 - 1.2 mm / 4 m	7025541012
	M8 x 1.0 x L30 mm	7023083010		1.0 - 1.2 mm / 5 m	7025551012
	M8 x 1.2 x L30 mm	7023083012		1.2 - 1.6 mm / 3 m	7025531216
4	Nozzle (Ø16 x 83 mm)	7022001684		1.2 - 1.6 mm / 4 m	7025541216
5	Steel Liner			1.2 - 1.6 mm / 5 m	7025551216
	1.0 - 1.2 mm / 3 m	7025031012	6	Swan Neck	Y522000562
	1.0 - 1.2 mm / 4 m	7025041012	7	Handle	Y522000559
	1.0 - 1.2 mm / 5 m	7025051012	8	Trigger Switch	Y522000560
	1.2 - 1.6 mm / 3 m	7025031216	9	Euro Connector	Y522000561

Air Cooled MIG Torch

Lava MIG 40

340A CO₂ 300A mix gas, EN60974-7 @ %60 Duty Cycle, 1.00 – 1.60 mm Wire Diameter

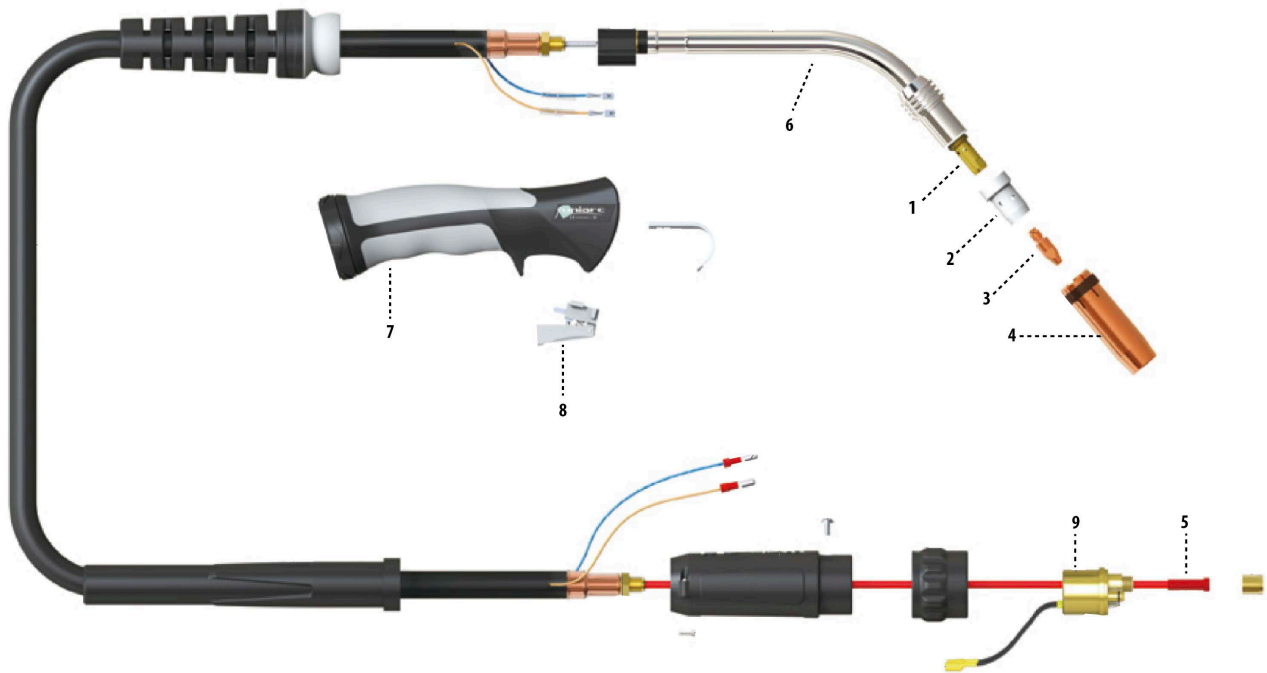

Model	Product Code		
	3 m	4 m	5 m
Lava MIG 40	7120040003	7120040004	7120040005

Consumables					
Part No.	Product Name	Product Code	Part No.	Product Name	Product Code
1	Tip Holder (M8)	7026000408	5	Steel Liner	
2	Gas Diffuser	7024100050		1.6 - 2.4 mm / 3 m	7025032024
3	Contact Tips			1.6 - 2.4 mm / 4 m	7025042024
	M8 x 0.8 x L30 mm	7023083008		1.6 - 2.4 mm / 5 m	7025052024
	M8 x 1.0 x L30 mm	7023083010	5	Teflon Liner	
	M8 x 1.2 x L30 mm	7023083012		1.0 - 1.2 mm / 3 m	7025531012
	M8 x 1.6 x L30 mm	7023083016		1.0 - 1.2 mm / 4 m	7025541012
4	Nozzle (Ø16 x 76 mm)	7022001675		1.0 - 1.2 mm / 5 m	7025551012
5	Steel Liner			1.2 - 1.6 mm / 3 m	7025531216
	1.0 - 1.2 mm / 3 m	7025031012		1.2 - 1.6 mm / 4 m	7025541216
	1.0 - 1.2 mm / 4 m	7025041012		1.2 - 1.6 mm / 5 m	7025551216
	1.0 - 1.2 mm / 5 m	7025051012	6	Swan Neck	Y522000565
	1.2 - 1.6 mm / 3 m	7025031216	7	Handle	Y522000559
	1.2 - 1.6 mm / 4 m	7025041216	8	Trigger Switch	Y522000560
	1.2 - 1.6 mm / 5 m	7025051216	9	Euro Connector	Y522000561

Water Cooled MIG Torch

Lava MIG 50W

500A CO₂ 450A mix gas, EN60974-7 @ %100 Duty Cycle, 1.00 – 1.60 mm Wire Diameter

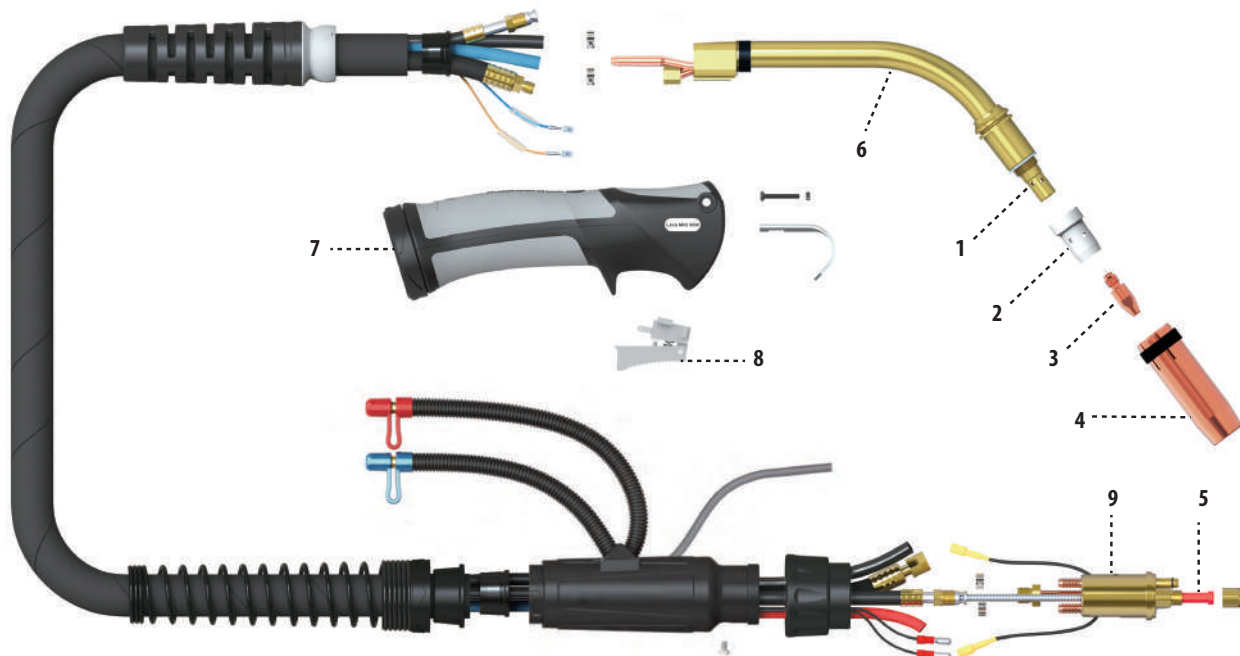

Model	Product Code		
	3 m	4 m	5 m
Lava MIG 50W	7120050003	7120050004	7120050005

Consumables					
Part No.	Product Name	Product Code	Part No.	Product Name	Product Code
1	Tip Holder (M8)	7026000508	5	Steel Liner	
2	Gas Diffuser	7024100050		1.6 - 2.4 mm / 3 m	7025032024
3	Contact Tips			1.6 - 2.4 mm / 4 m	7025042024
	M8 x 0.8 x L30 mm	7023083008		1.6 - 2.4 mm / 5 m	7025052024
	M8 x 1.0 x L30 mm	7023083010	5	Teflon Liner	
	M8 x 1.2 x L30 mm	7023083012		1.0 - 1.2 mm / 3 m	7025531012
	M8 x 1.6 x L30 mm	7023083016		1.0 - 1.2 mm / 4 m	7025541012
	M8 x 2.0 x L30 mm	7023083020		1.0 - 1.2 mm / 5 m	7025551012
	M8 x 2.4 x L30 mm	7023083024		1.2 - 1.6 mm / 3 m	7025531216
4	Nozzle (Ø16 x 76 mm)	7022001675		1.2 - 1.6 mm / 4 m	7025541216
5	Steel Liner			1.2 - 1.6 mm / 5 m	7025551216
	1.0 - 1.2 mm / 3 m	7025031012		1.6 - 2.0 mm / 3 m	7025531620
	1.0 - 1.2 mm / 4 m	7025041012		1.6 - 2.0 mm / 4 m	7025541620
	1.0 - 1.2 mm / 5 m	7025051012		1.6 - 2.0 mm / 5 m	7025551620
	1.2 - 1.6 mm / 3 m	7025031216	6	Swan Neck	Y522000566
	1.2 - 1.6 mm / 4 m	7025041216	7	Handle	Y522000559
	1.2 - 1.6 mm / 5 m	7025051216	8	Trigger Switch	Y522000560
			9	Euro Connector	Y522000561

Water Cooled MIG Torch

Lava MIG 65W

550A CO₂ 500A mix gas, EN60974-7 @ %100 Duty Cycle, 1.00 – 1.60 mm Wire Diameter

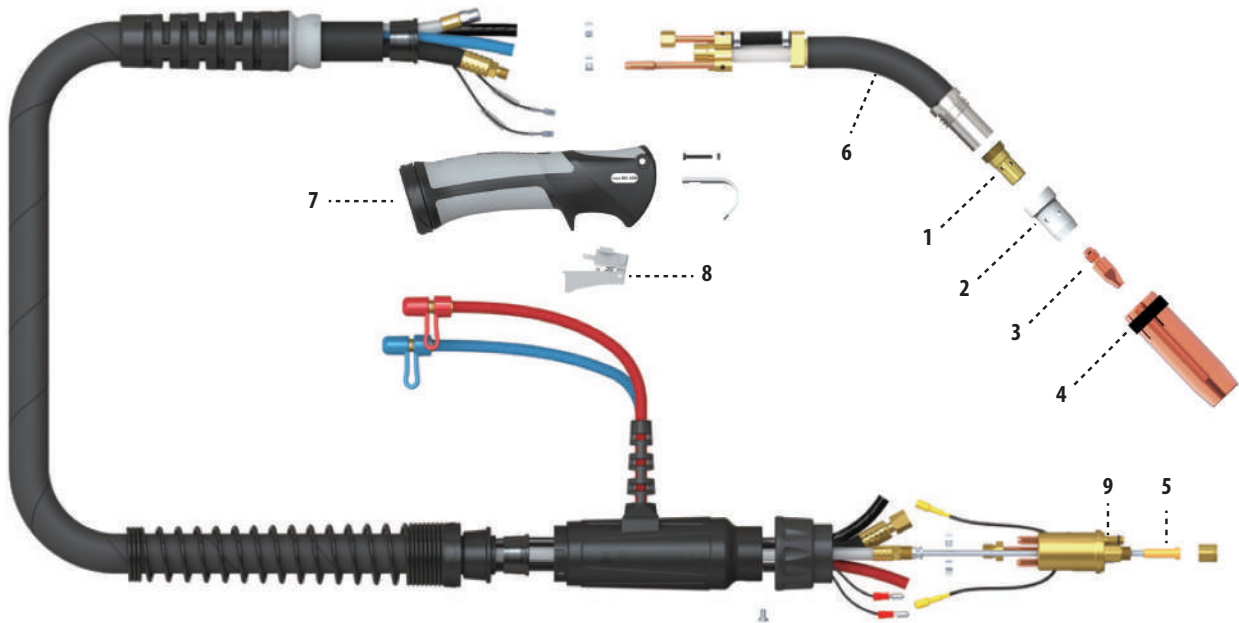

Model	Product Code		
	3 m	4 m	5 m
Lava MIG 65W	7120160003	7120160004	7120160005

Consumables					
Part No.	Product Name	Product Code	Part No.	Product Name	Product Code
1	Tip Holder (M10)	7026000610	6	Steel Liner	
2	Gas Diffuser	7024100065		1.6 - 2.4 mm / 3 m	7025031624
3	Contact Tips			1.6 - 2.4 mm / 4 m	7025041624
	M10 x 1.0 x L35 mm	7023213510		1.6 - 2.4 mm / 5 m	7025051624
	M10 x 1.2 x L35 mm	7023213512	6	Teflon Liner	
	M10 x 1.6 x L35 mm	7023213516		1.0 - 1.2 mm / 3 m	7025531012
	M10 x 2.0 x L35 mm	7023213520		1.0 - 1.2 mm / 4 m	7025541012
	M10 x 2.4 x L35 mm	7023213524		1.0 - 1.2 mm / 5 m	7025551012
	M10 x 2.8 x L30 mm	7023213528		1.2 - 1.6 mm / 3 m	7025531216
4	Nozzle Adapter	7023002821		1.2 - 1.6 mm / 4 m	7025541216
5	Nozzle (Ø17 x 77 mm)	7022101777		1.2 - 1.6 mm / 5 m	7025551216
6	Steel Liner			1.6 - 2.0 mm / 3 m	7025531620
	1.0 - 1.2 mm / 3 m	7025031012		1.6 - 2.0 mm / 4 m	7025541620
	1.0 - 1.2 mm / 4 m	7025041012		1.6 - 2.0 mm / 5 m	7025551620
	1.0 - 1.2 mm / 5 m	7025051012	7	Swan Neck	Y522000567
	1.2 - 1.6 mm / 3 m	7025031216	8	Handle	Y522000558
	1.2 - 1.6 mm / 4 m	7025041216	9	Trigger Switch	Y522000560
	1.2 - 1.6 mm / 5 m	7025051216	10	Euro Connector	Y522000561

Lava TIG Series

Magmaweld TIG torches that will take you to the top in lightness and ergonomics.

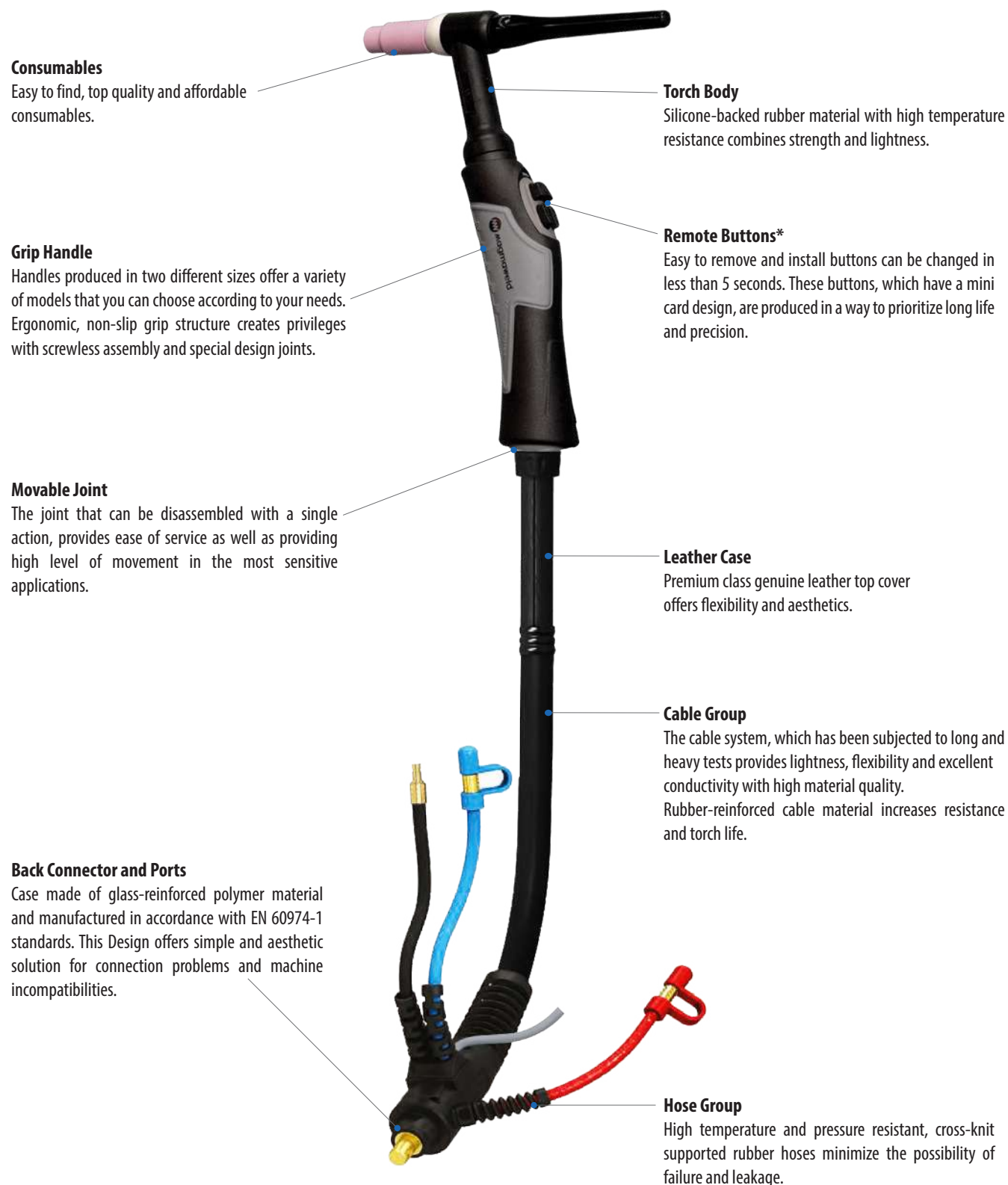

Consumables

Easy to find, top quality and affordable consumables.

Torch Body

Silicone-backed rubber material with high temperature resistance combines strength and lightness.

Grip Handle

Handles produced in two different sizes offer a variety of models that you can choose according to your needs. Ergonomic, non-slip grip structure creates privileges with screwless assembly and special design joints.

Remote Buttons*

Easy to remove and install buttons can be changed in less than 5 seconds. These buttons, which have a mini card design, are produced in a way to prioritize long life and precision.

Movable Joint

The joint that can be disassembled with a single action, provides ease of service as well as providing high level of movement in the most sensitive applications.

Leather Case

Premium class genuine leather top cover offers flexibility and aesthetics.

Cable Group

The cable system, which has been subjected to long and heavy tests provides lightness, flexibility and excellent conductivity with high material quality. Rubber-reinforced cable material increases resistance and torch life.

Back Connector and Ports

Case made of glass-reinforced polymer material and manufactured in accordance with EN 60974-1 standards. This Design offers simple and aesthetic solution for connection problems and machine incompatibilities.

Hose Group

High temperature and pressure resistant, cross-knit supported rubber hoses minimize the possibility of failure and leakage.

*It varies according to the model.

TIG Torches

Lava TIG Series

Magmaweld TIG torches will take you to the top at ergonomics and lightness.



Technical Specifications		Lava TIG 9	Lava TIG 17	Lava TIG 26	Lava TIG 24	Lava TIG 20W	Lava TIG 18W
Current	DC	125 A	150 A	180 A	180 A	225 A	380 A
	AC	90 A	105 A	125 A	125 A	160 A	270 A
Duty Cycle		%35	%35	%35	%35	%100	%100
Cooling Type		Air	Air	Air	Air	Water	Water
Product Codes	Torch 4 m	7110012504	7110013504	7110018004	7110018104	7110022504	7110022508
	8 m	7110012508	7110013508	7110018008	7110018108	7110022508	7110038008
	Regulator	7020001004					

Lava TIG 9

125A DC, EN60974-7 @ %35 Duty Cycle

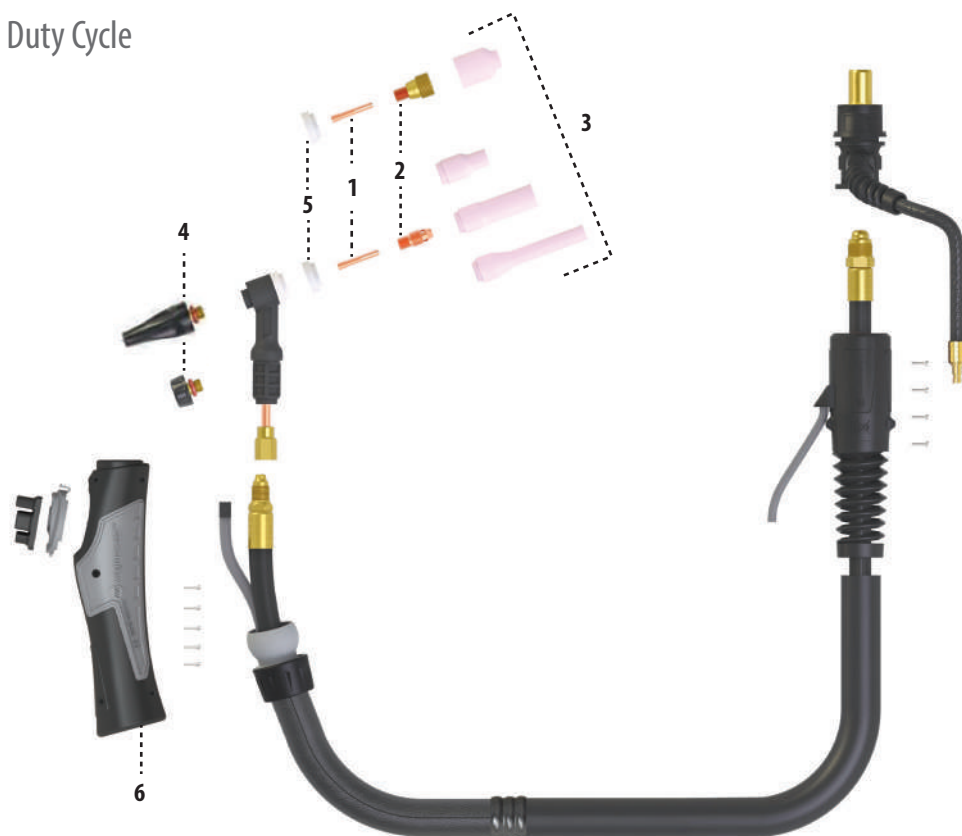

Model	Product Code	
	4 m	8 m
Lava TIG 9	7111040125	7111080125

Consumables					
Part No.	Product Name	Product Code	Part No.	Product Name	Product Code
1	Collet		3	Ceramic Nozzle	
	1.0 mm	7012010010		Ø11 - L30 mm No: 7	7014021107
	1.6 mm	7012010016		Ø12.5 - L30 mm No: 8	7014021208
	2.0 mm	7012010020		Ø16 - L30 mm No: 10	7014021610
	2.4 mm	7012010024		Ø5 - L48 mm No: 3 (Long)	7014030503
2	Collet Body			Ø6 - L48 mm No: 4 (Long)	7014030604
	1.0 mm	7013010110		Ø8 - L48 mm No: 5 (Long)	7014030805
	1.6 mm	7013010116		Ø10 - L48 mm No: 6 (Long)	7014031006
	2.0 mm	7013010120		Ø6 - L25 mm No: 4 (with lens)	7014140604
	2.4 mm	7013010124		Ø8 - L25 mm No: 5 (with lens)	7014140805
	1.0 mm (with lens)	7016010010		Ø10 - L25 mm No: 6 (with lens)	7014141006
	1.6 mm (with lens)	7016010016		Ø11 - L25 mm No: 7 (with lens)	7014141107
	2.0 mm (with lens)	7016010020		Ø12.5 - L25 mm No: 8 (with lens)	7014141208
	2.4 mm (with lens)	7016010024		4	Back Cap
3	Ceramic Nozzle		5	Insulator	7017000103
	Ø6 - L30 mm No: 4	7014020604	6	Handle	Y512000269
	Ø8 - L30 mm No: 5	7014020805	7	Trigger	7910000001
	Ø10 - L30 mm No: 6	7014021006			

Air Cooled TIG Torch

Lava TIG 17

150A DC, EN60974-7 @ %35 Duty Cycle

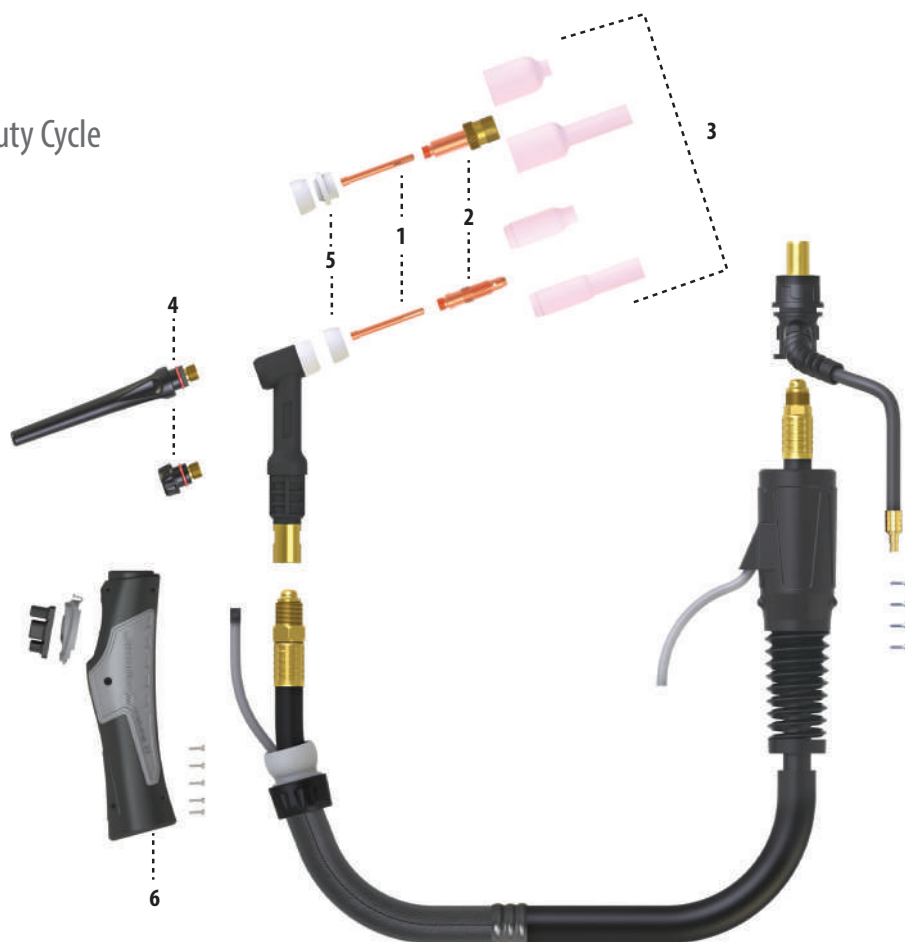

Model	Product Code	
Lava TIG 17	4 m	8 m
	7110013504	7110013508

Consumables							
Part No.	Product Name	Product Code	Part No.	Product Name	Product Code		
1	Collet		3	Ceramic Nozzle			
	1.6 mm	7012000016		Ø6 - L46 mm No: 4	7014000604		
	2.0 mm	7012000020		Ø8 - L46 mm No: 5	7014000805		
	2.4 mm	7012000024		Ø10 - L46 mm No: 6	7014001006		
	3.2 mm	7012000032		Ø11 - L46 mm No: 7	7014001107		
4.0 mm	7012000040	Ø12.5 - L46 mm No: 8		7014001108			
2	Collet Body			Ø16 - L46 mm No: 10	7014001610		
	1.0 mm	7013000110		Ø8 - L76 mm No: 5 (Long)	7014010805		
	1.6 mm	7013000116		Ø10 - L76 mm No: 6 (Long)	7014011006		
	2.0 mm	7013000120		Ø11 - L76 mm No: 7 (Long)	7014011107		
	2.4 mm	7013000124		4	Back Cap (Long)	7015000101	
	3.2 mm	7013000132			Back Cap (Short)	7015000102	
	4.0 mm	7013000140		5	Insulator	7017000101	
	1.0 mm (with lens)	7016000010			Insulator (with lens)	7017000102	
	1.6 mm (with lens)	7016000016		6	Handle	Y512000270	
	2.0 mm (with lens)	7016000020			7	Trigger	7910000001
	2.4 mm (with lens)	7016000024					
	3.2 mm (with lens)	7016000032					
4.0 mm (with lens)	7016000040						

Lava TIG 26

180A DC, EN60974-7 @ %35 Duty Cycle

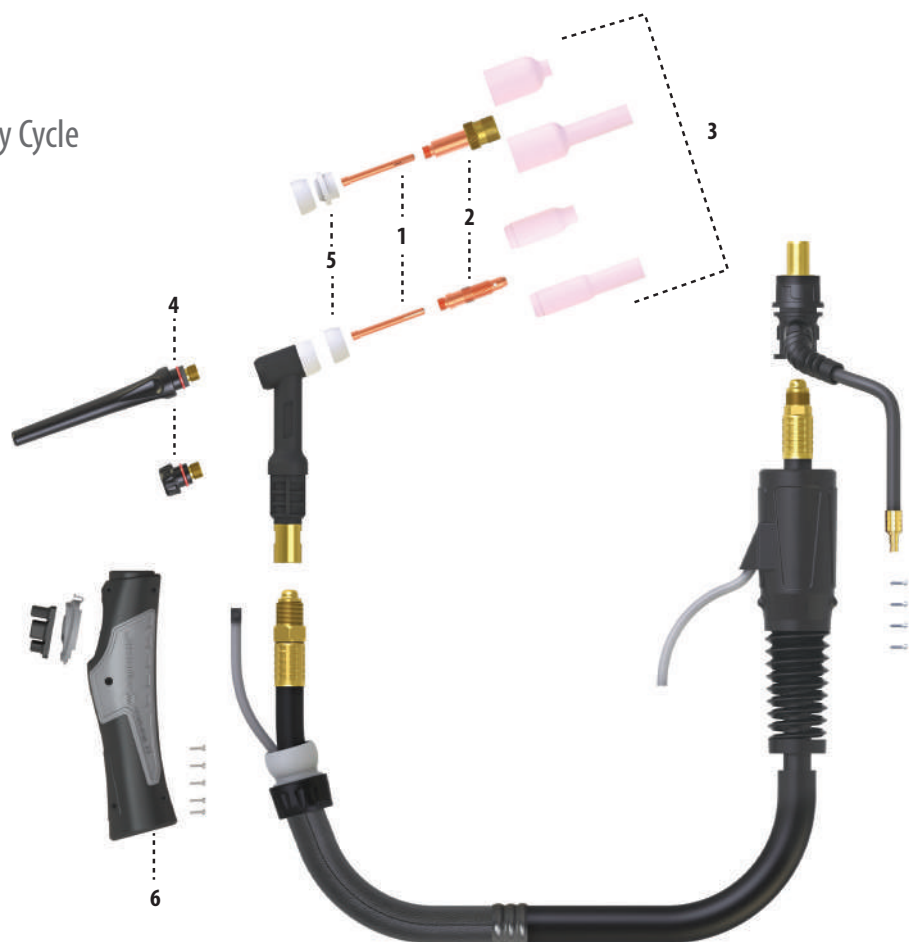

Model	Product Code	
	4 m	8 m
Lava TIG 26	7110018004	7110018008

Consumables						
Part No.	Product Name	Product Code	Part No.	Product Name	Product Code	
1	Collet		3	Ceramic Nozzle		
	1.6 mm	7012010016		Ø6 - L46 mm No: 4	7014000604	
	2.0 mm	7012010020		Ø8 - L46 mm No: 5	7014000805	
	2.4 mm	7012010024		Ø10 - L46 mm No: 6	7014001006	
	3.2 mm	7012000032		Ø11 - L46 mm No: 7	7014001107	
4.0 mm	7012000040	Ø12.5 - L46 mm No: 8		7014001108		
2	Collet Body			Ø16 - L46 mm No: 10	7014001610	
	1.0 mm	7013000110		Ø8 - L76 mm No: 5 (Long)	7014010805	
	1.6 mm	7013000116		Ø10 - L76 mm No: 6 (Long)	7014011006	
	2.0 mm	7013000120		Ø11 - L76 mm No: 7 (Long)	7014011006	
	2.4 mm	7013000124		4	Back Cap (Long)	7015000101
	3.2 mm	7013000132	Back Cap (Short)		7015000102	
	4.0 mm	7013000140	5	Insulator	7017000101	
	1.0 mm (with lens)	7016000010		Insulator (with lens)	7017000102	
	1.6 mm (with lens)	7016000016	6	Handle	Y512000270	
	2.0 mm (with lens)	7016000020		7	Trigger	7910000001
	2.4 mm (with lens)	7016000024				
	3.2 mm (with lens)	7016000032				
	4.0 mm (with lens)	7016000040				

Air Cooled TIG Torch

Lava TIG 24

180A DC, EN60974-7 @ %35 Duty Cycle

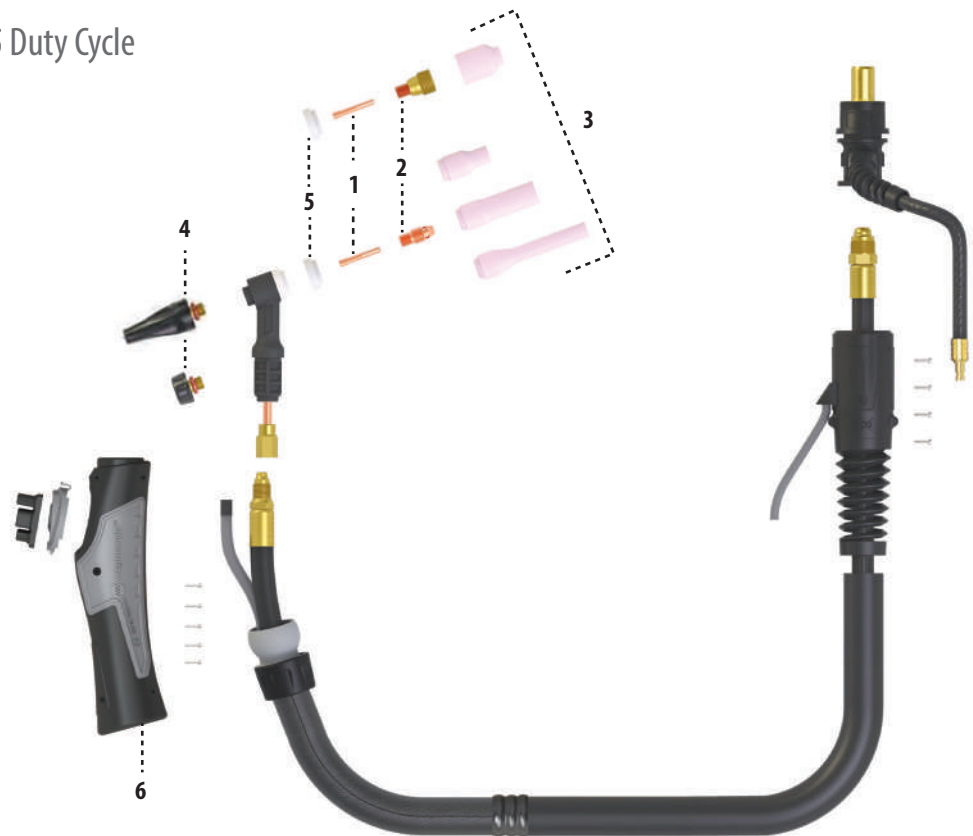

Model	Product Code	
	4 m	8 m
Lava TIG 24	7110018104	7110018108

Consumables					
Part No.	Product Name	Product Code	Part No.	Product Name	Product Code
1	Collet		4	Back Cap (Long)	7015000103
	1.0 mm	7012020010		Back Cap (Short)	7015000104
	1.6 mm	7012020016	5	Insulator	7017000104
	1.6 mm (with lens)	7012100016		Insulator (with lens)	7017000105
2	Collet Body		6	Handle	Y512000269
	1.0 mm	7013020110	7	Trigger	7910000001
	1.6 mm	7013020116			
	1.0 mm (with lens)	7016010010			
	1.6 mm (with lens)	7016010016			
3	Ceramic Nozzle				
	Ø6 - L17 mm No: 4	7014150604			
	Ø8 - L17 mm No: 5	7014150805			
	Ø10 - L17 mm No: 6	7014151006			
	Ø6 - L25 mm No: 4 (with lens)	7014140604			
	Ø8 - L25 mm No: 5 (with lens)	7014140805			
	Ø10 - L25 mm No: 6 (with lens)	7014141006			
	Ø11 - L25 mm No: 7 (with lens)	7014141107			
Ø12.5 - L25 mm No: 8 (with lens)	7014141208				

Water Cooled TIG Torch

Lava TIG 20W

225A DC, EN60974-7 @ %100 Duty Cycle

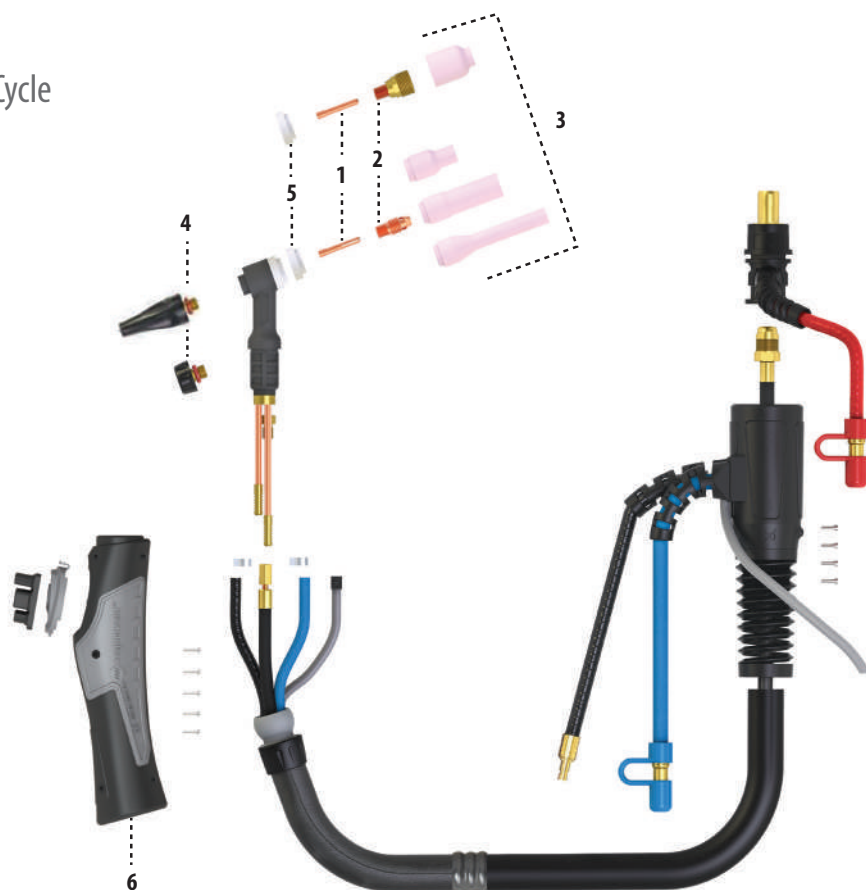

Model	Product Code	
	4 m	8 m
Lava TIG 20W	7110022504	7110022508

Consumables					
Part No.	Product Name	Product Code	Part No.	Product Name	Product Code
1	Collet		3	Ceramic Nozzle	
	1.0 mm	7012010010		Ø11 - L30 mm No: 7	7014021107
	1.6 mm	7012010016		Ø12.5 - L30 mm No: 8	7014021208
	2.0 mm	7012010020		Ø16 - L30 mm No: 10	7014021610
	2.4 mm	7012010024		Ø5 - L48 mm No: 3 (Long)	7014030503
2	Collet Body			Ø6 - L48 mm No: 4 (Long)	7014030604
	1.0 mm	7013010110		Ø8 - L48 mm No: 5 (Long)	7014030805
	1.6 mm	7013010116		Ø10 - L48 mm No: 6 (Long)	7014031006
	2.0 mm	7013010120		Ø6 - L25 mm No: 4 (with lens)	7014140604
	2.4 mm	7013010124		Ø8 - L25 mm No: 5 (with lens)	7014140805
	1.0 mm (with lens)	7016010010		Ø10 - L25 mm No: 6 (with lens)	7014141006
	1.6 mm (with lens)	7016010016		Ø11 - L25 mm No: 7 (with lens)	7014141107
	2.0 mm (with lens)	7016010020	Ø12.5 - L25 mm No: 8 (with lens)	7014141208	
	2.4 mm (with lens)	7016010024	4	Back Cap (Long)	7015000103
3	Ceramic Nozzle			Back Cap (Short)	7015000104
	Ø6 - L30 mm No: 4	7014020604	5	Insulator	7017000103
	Ø8 - L30 mm No: 5	7014020805	6	Handle	Y512000269
	Ø10 - L30 mm No: 6	7014021006	7	Trigger	7910000001

Water Cooled TIG Torch

Lava TIG 18W

380A DC, EN60974-7 @ %100 Duty Cycle

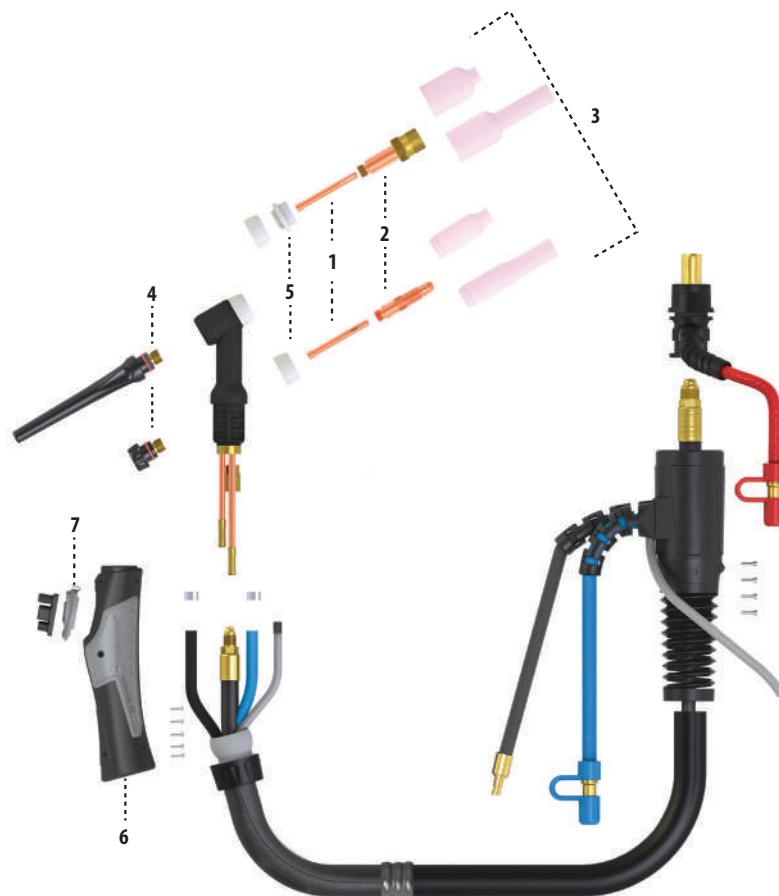

Model	Product Code	
	4 m	8 m
Lava TIG 18W	7110038004	7110038008

Consumables						
Part No.	Product Name	Product Code	Part No.	Product Name	Product Code	
1	Collet		3	Ceramic Nozzle		
	1.6 mm	7012000016		Ø6 - L46 mm No: 4	7014000604	
	2.0 mm	7012000020		Ø8 - L46 mm No: 5	7014000805	
	2.4 mm	7012000024		Ø10 - L46 mm No: 6	7014001006	
	3.2 mm	7012000032		Ø11 - L46 mm No: 7	7014001107	
4.0 mm	7012000040	Ø12.5 - L46 mm No: 8		7014001108		
2	Collet Body			Ø16 - L46 mm No: 10	7014001610	
	1.0 mm	7013000110		Ø8 - L76 mm No: 5 (Long)	7014010805	
	1.6 mm	7013000116		Ø10 - L76 mm No: 6 (Long)	7014011006	
	2.0 mm	7013000120		Ø11 - L76 mm No: 7 (Long)	7014011107	
	2.4 mm	7013000124		4	Back Cap (Long)	7015000101
	3.2 mm	7013000132			Back Cap (Short)	7015000102
	4.0 mm	7013000140		5	Insulator	7017000101
	1.0 mm (with lens)	7016000010			Insulator (with lens)	7017000102
	1.6 mm (with lens)	7016000016		6	Handle	Y512000270
	2.0 mm (with lens)	7016000020	7	Trigger	7910000001	
2.4 mm (with lens)	7016000024					
3.2 mm (with lens)	7016000032					

Plasma Torches

Lava CUT Series

For upgrading to high cutting power
Magmaweld Plasma torches



Consumables

High-quality, long-lasting consumables has been specially designed and produced with the latest technology. Thanks to its compatibility with brands in the market, offers high price / performance solutions.

Torch Handle

With high temperature resistance durable grip design, combines strength and lightness

Trigger Mechanism

With high strength trigger safety lock It prevents work accidents.

Cable Group

The cable system which subjected to long and heavy tests provides lightness, flexibility and excellent conductivity with its high quality materials. Rubber coated cable material, increases the strength and extends the life of the torch.

Rear Connector

Connector case made of glass-reinforced polymer material and manufactured according to standards. Connector design offers a simple and aesthetic solution to eliminate problems and removes machine incompatibilities. With the Euro Connector structure, It also provides compatibility with other brands.

Plasma Torches

Plasma Hand Cutting Torch

10-35 A, %60 (35 A) Duty Cycle, Gas: Air,

Working Pressure (Cutting): 3,5 bar

Gas Flow (35 A): 295 lt/min.

Ignition: Without HF



Model	Product Code
Lava CUT Mini Torch	4 m 7142H03004
Manual Consumables Kit (miniCUT)	7942000300

Plasma Torches

Plasma Hand Cutting Torch

40-125 A, %60 (125 A) Duty Cycle, Gas: Air / N₂,

Working Pressure (Cutting): 5-6 bar

Working Pressure (Gouging): 4-4,5 bar

Gas Flow (125 A): 295 lt/min.

Ignition: Without HF



Model	Product Code	
	6 m	12 m
Lava CUT Manual Torch	7142H10506	7142H10512

Plasma Mechanized Cutting Torch

40-125 A, %60 (125 A) Duty Cycle, Gas: Air / N₂,

Working Pressure (Cutting): 5-6 bar

Working Pressure (Gouging): 4-4,5 bar

Gas Flow (125 A): 295 lt/min.

Ignition: Without HF



Model	Product Code	
	6 m	12 m
Lava CUT Mechanized Torch	7142H10506	7142H10512
Mechanized Torch Tube (Rack System)	7942000010	7942000010

MIG Torch Consumables

Nozzles	Product Code	Product Name	Bore (Ø)	Compatible Lava MIG Torches					
				15	25	35	40	50W/WR	65W
	7022021653	Cylindric Nozzle	16.0	●					
	7022001253	Conical Nozzle	12.0	●					
	7022011053	Narrow Nozzle	10.5	●					
	7022031353	Bottle Nozzle	12.8	●					
	7022021857	Cylindric Nozzle	18.0		●				
	7022001554	Conical Nozzle	15.0		●				
	7022011253	Narrow Nozzle	12.0		●				
	7022031457	Bottle Nozzle	14.5		●				
	7022021983	Cylindric Nozzle	19.0			●			
	7022001684	Conical Nozzle	16.1			●			
	7022011283	Narrow Nozzle	12.0			●			
	7022021976	Cylindric Nozzle	19.0				●	●	
	7022001675	Conical Nozzle	16.0				●	●	
	7022011476	Narrow Nozzle	14.0				●	●	
	7022101777	Conical Nozzle 2.6	17.0						●

Contact Tips	Product Code	Product Name	Diameter(mm)	Compatible Lava MIG Torches					
				15	25	35	40	50W/WR	65W
	7023062506	Contact Tip	0.6 - 0.023 x M6	●					
	7023062508	Contact Tip	0.8 - 0.030 x M6	●					
	7023062510	Contact Tip	1.0 - 0.040 x M6	●					
	7023062512	Contact Tip	1.2 - 0.045 x M6	●					
	7023062806	Contact Tip	0.6 - 0.023 x M6		●	●			
	7023062808	Contact Tip	0.8 - 0.030x M6		●	●			
	7023062810	Contact Tip	1.0 - 0.040 x M6		●	●			
	7023062812	Contact Tip	1.2 - 0.045 x M6		●	●			
	7023062814	Contact Tip	1.4 - 0.055 x M6		●	●			
	7023062816	Contact Tip	1.6 - 0.063 x M6		●	●			
	7023162808	Contact Tip (Al)	0.8 - 0.040 x M6		●	●			
	7023162810	Contact Tip (Al)	1.0 - 0.045 x M6		●	●			
7023162812	Contact Tip (Al)	1.2 - 0.063 x M6		●	●				
	7023262808	Contact Tip(CuCrZr)	0.8 - 0.030 x M6		●	●			
	7023262810	Contact Tip (CuCrZr)	1.0 - 0.040 x M6		●	●			
	7023262812	Contact Tip (CuCrZr)	1.2 - 0.045 x M6		●	●			

- Standard
- Optional

MIG Torch Consumables

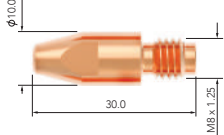
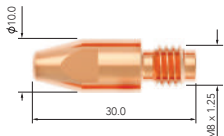
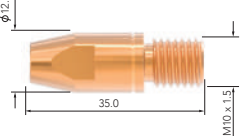

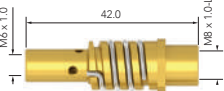
Contact Tips	Product Code	Product Name	Diameter(mm)	Compatible Lava MIG Torches					
				15	25	35	40	50W/WR	65W
	7023083008	Contact Tip	0.8 - 0.030 x M8			●	●	●	
	7023083010	Contact Tip	1.0 - 0.040 x M8			●	●	●	
	7023083012	Contact Tip	1.2 - 0.045 x M8			●	●	●	
	7023083014	Contact Tip	1.4 - 0.055 x M8			●	●	●	
	7023083016	Contact Tip	1.6 - 0.063 x M8			●	●	●	
	7023083020	Contact Tip	2.0 - 0.080 x M8			●	●	●	
	7023183008	Contact Tip (Al)	0.8 - 0.035 x M8			●	●	●	
	7023183010	Contact Tip (Al)	1.0 - 0.045 x M8			●	●	●	
	7023183012	Contact Tip (Al)	1.2 - 0.063 x M8			●	●	●	
	7023283010	Contact Tip (CuCrZr)	1.0 - 0.040 x M8			●		●	
	7023283012	Contact Tip (CuCrZr)	1.2 - 0.045 x M8			●		●	
	7023283016	Contact Tip (CuCrZr)	1.6 - 0.063 x M8			●		●	
	7023283024	Contact Tip (CuCrZr)	2.4 - 0.095 x M8			●		●	
	7023213512	Contact Tip (CuCrZr)	1.2 - 0.045 x M10						●
	7023213514	Contact Tip (CuCrZr)	1.4 - 0.055 x M10						●
	7023213516	Contact Tip (CuCrZr)	1.6 - 0.063 x M10						●
	7023213520	Contact Tip (CuCrZr)	2.0 - 0.080 x M10						●
	7023213524	Contact Tip (CuCrZr)	2.4 - 0.095 x M10						●

Contact Tip Holders	Product Code	Product Name	Compatible Lava MIG Torches						
			15	25	35	40	50W/WR	65W	
	7026000156	Tip Holder M6	●						
	7026000256	Tip Holder M6		●					

- Standard
- Optional

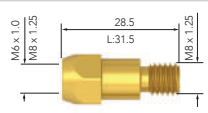
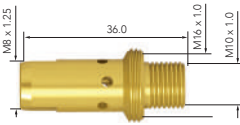
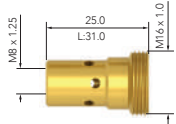
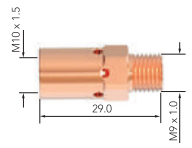

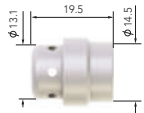
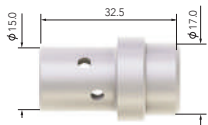
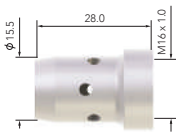

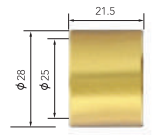



















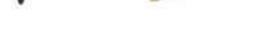

MIG Torch Consumables

Contact Tip Holders	Product Code	Product Name	Compatible Lava MIG Torches					
			15	25	35	40	50W/WR	65W
	7026000156	Tip Holder M6			●			
	7026000256	Tip Holder M6			●			
	7026000408	Tip Holder M8				●		
	7026000508	Tip Holder M8					●	
	7026000610	Tip Holder M10						●

Gas Diffusers	Product Code	Product Name	Compatible Lava MIG Torches					
			15	25	35	40	50W/WR	65W
	7024100024	Gas Diffuser / White		●				
	7024100035	Gas Diffuser / White			●			
	7024100050	Gas Diffuser / White				●	●	
	7024100065	Gas Diffuser / Black						●
	7022302821	Nozzle Adapter / Brass						●



- Standard
- Optional

MIG Torch Consumables

Lineers	Product Code	Product Name	Diameter(mm)	Compatible Lava MIG Torches					
				15	25	35	40	50W/WR	65W
	7025030609	Steel Liner / 3 m	0.6-0.9	●	●				
	7025040609	Steel Liner / 4 m	0.6-0.9	●	●				
	7025031012	Steel Liner / 3 m	1.0-1.2		●	●	●		
	7025041012	Steel Liner / 4 m	1.0-1.2		●	●	●		
	7025051012	Steel Liner / 5 m	1.0-1.2		●	●	●		
	7025031216	Steel Liner / 3 m	1.6			●	●		
	7025041216	Steel Liner / 4 m	1.6			●	●		
	7025051216	Steel Liner / 5 m	1.6			●	●		
	7025032024	Steel Liner / 3 m	1.6-2.4			●	●		
	7025042024	Steel Liner / 4 m	1.6-2.4			●	●		
	7025052024	Steel Liner / 5 m	1.6-2.4			●	●		
	7025131012	Steel Liner / 3 m	1.0-1.2				●	●	●
	7025141012	Steel Liner / 4 m	1.0-1.2				●	●	●
	7025151012	Steel Liner / 5 m	1.0-1.2				●	●	●
	7025131216	Steel Liner / 3 m	1.2-1.6				●	●	●
	7025141216	Steel Liner / 4 m	1.2-1.6				●	●	●
	7025151216	Steel Liner / 5 m	1.2-1.6				●	●	●
	7025530610	Teflon Liner / 3 m	0.6-0.9	●	●	●			
	7025540610	Teflon Liner / 4 m	0.6-0.9	●	●	●			
	7025550609	Teflon Liner / 5 m	0.6-0.9	●	●	●			
	7025531012	Teflon Liner / 3 m	1.0-1.2		●	●	●	●	●
	7025541012	Teflon Liner / 4 m	1.0-1.2		●	●	●	●	●
	7025551012	Teflon Liner / 5 m	1.0-1.2		●	●	●	●	●
	7025531216	Teflon Liner / 3 m	1.2-1.6			●	●	●	●
	7025541216	Teflon Liner / 4 m	1.2-1.6			●	●	●	●
	7025551216	Teflon Liner / 5 m	1.2-1.6			●	●	●	●

- Standard
- Optional

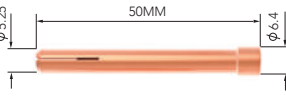
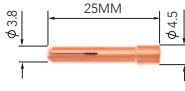

TIG Torch Consumables

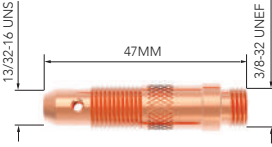
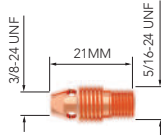
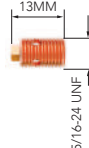
Collets	Product Code	Product Name	Diameter (mm)	Diameter (inch)	Compatible Lava TIG Torches					
					9	17	26	24	20W	18W
	7012000016	Collet	1.6	1/16"		●	●			●
	7012000020	Collet	2.0	5/64"		●	●			●
	7012000024	Collet	2.4	3/32"		●	●			●
	7012000032	Collet	3.2	1/8"		●	●			●
	7012000040	Collet	4.0	5/32"		●	●			●
	7012010010	Collet	1.0	0.04"	●				●	
	7012010016	Collet	1.6	1/16"	●				●	
	7012010020	Collet	2.0	5/64"	●				●	
	7012010024	Collet	2.4	3/32"	●				●	
	7012020010	Collet	1.0	0.04"				●		
	7012020016	Collet	1.6	1/16"				●		

Collet Bodies	Product Code	Product Name	Diameter (mm)	Diameter (inch)	Compatible Lava TIG Torches					
					9	17	26	24	20W	18W
	7013000110	Collet Body	1.0	0.04"		●	●			●
	7013000116	Collet Body	1.6	1/16"		●	●			●
	7013000120	Collet Body	2.0	5/64"		●	●			●
	7013000124	Collet Body	2.4	3/32"		●	●			●
	7013000132	Collet Body	3.2	1/8"		●	●			●
	7013010110	Collet Body	1.0	0.04"	●				●	
	7013010116	Collet Body	1.6	1/16"	●				●	
	7013010120	Collet Body	2.0	5/64"	●				●	
	7013010124	Collet Body	2.4	3/32"	●				●	
	7013020110	Collet Body	1.0	0.04"				●		
	7013020116	Collet Body	1.6	1/16"				●		

- Standard
- Optional

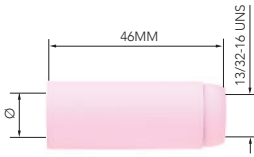

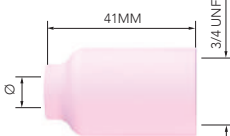
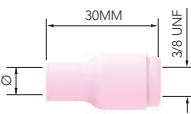
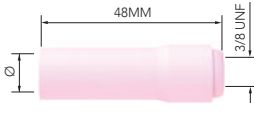
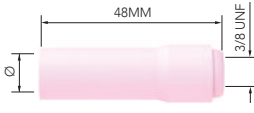
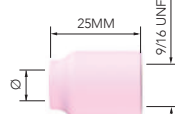
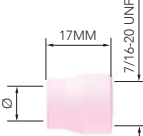

TIG Torch Consumables



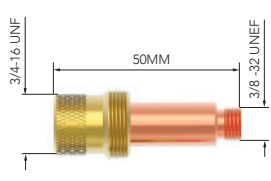
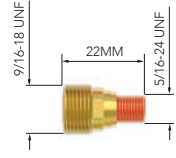

Ceramic Nozzles	Product Code	Product Name	No	Ø (mm)	Diameter (inch)	Compatible Lava TIG Torches					
						9	17	26	24	20W	18W
	7014001610	Ceramic Nozzle	10	16	5/8"		●	●			●
	7014001108	Ceramic Nozzle	8	12.5	1/2"		●	●			●
	7014001107	Ceramic Nozzle	7	11	7/16"		●	●			●
	7014001006	Ceramic Nozzle	6	10	3/8"		●	●			●
	7014000805	Ceramic Nozzle	5	8	5/16"		●	●			●
	7014000604	Ceramic Nozzle	4	6	1/4"		●	●			●
	7014011107	Long Ceramic Nozzle	7	11	7/16"		●	●			●
	7014011006	Long Ceramic Nozzle	6	10	3/8"		●	●			●
	7014010805	Long Ceramic Nozzle	5	8	5/8"		●	●			●
	7014111208	Ceramic Nozzle	8	12.5	1/2"		●	●			●
	7014111107	Ceramic Nozzle	7	11	7/16"		●	●			●
	7014119506	Ceramic Nozzle	6	10	3/8"		●	●			●
	7014110805	Ceramic Nozzle	5	8	5/16"		●	●			●
	7014116504	Ceramic Nozzle	4	6	1/4"		●	●			●
	7014111711	Ceramic Nozzle	11	17	11/16"		●	●			●
	7014020604	Ceramic Nozzle	4	6	1/4"	●	●	●		●	●
	7014020805	Ceramic Nozzle	5	8	5/16"	●	●	●		●	●
	7014021006	Ceramic Nozzle	6	10	3/8"	●	●	●		●	●
	7014021107	Ceramic Nozzle	7	11	7/16"	●	●	●		●	●
	7014021208	Ceramic Nozzle	4	12.5	1/2"	●	●	●		●	●
	7014021610	Ceramic Nozzle	10	16	5/8"	●	●	●		●	●
	7014030503	Long Ceramic Nozzle	3	5	3/16"	●				●	
	7014030604	Long Ceramic Nozzle	4	6	1/4"	●				●	
	7014030805	Long Ceramic Nozzle	5	8	5/16"	●				●	
	7014031006	Long Ceramic Nozzle	6	10	3/8"	●				●	
	7014140604	Ceramic Nozzle	4	6	1/4"	●	●	●	●	●	●
	7014140805	Ceramic Nozzle	5	8	5/16"	●	●	●	●	●	●
	7014141006	Ceramic Nozzle	6	10	3/8"	●	●	●	●	●	●
	7014141107	Ceramic Nozzle	7	11	7/16"	●	●	●	●	●	●
	7014141208	Ceramic Nozzle	8	12.5	1/2"	●	●	●	●	●	●
	7014050604	Ceramic Nozzle	4	6	1/4"				●		
	7014050805	Ceramic Nozzle	5	8	5/16"				●		
	7014051006	Ceramic Nozzle	6	10	3/8"				●		

- Standard
- Optional

TIG Torch Consumables

Gas Lenses	Product Code	Product Name	Diameter (mm)	Diameter (inch)	Compatible Lava TIG Torches					
					9	17	26	24	20W	18W
	7016000010	Gas Lens	1.0	0.04"		●	●			●
	7016000016	Gas Lens	1.6	1/16"		●	●			●
	7016000020	Gas Lens	2.0	5/64"		●	●			●
	7016000024	Gas Lens	2.4	3/32"		●	●			●
	7016000032	Gas Lens	3.2	1/8"		●	●			●
	7016010010	Gas Lens	1.0	0.04"	●				●	
	7016010016	Gas Lens	1.6	1/16"	●				●	
	7016010020	Gas Lens	2.0	5/64"	●				●	
	7016010024	Gas Lens	2.4	3/32"	●				●	
	7016010032	Gas Lens	3.2	1/8"	●				●	



Insulators	Product Code	Product Name	Compatible Lava TIG Torches					
			9	17	26	24	20W	18W
	7017000101	Insulator		●	●			●
	7017000102	Insulator		●	●			●
	7017000103	Insulator	●				●	
	7017000104	Insulator				●		
	7017000105	Insulator				●		

Back Caps	Product Code	Product Name	Compatible Lava TIG Torches					
			9	17	26	24	20W	18W
	7015000101	Back Cap (Long)		●	●			●
	7015000102	Back Cap (Short)		●	●			●
	7015000103	Back Cap (Long)	●			●	●	
	7015000104	Back Cap (Short)	●			●	●	

- Standard
- Optional





Tungsten Electrodes

Tungsten Electrodes	Product Code	Product Name	Diameter(mm)
	7018000116	Tungsten Electrode Red (Wt-20)	1.6 x 175 mm
	7018000120	Tungsten Electrode Red (Wt-20)	2.0 x 175 mm
	7018000124	Tungsten Electrode Red (Wt-20)	2.4 x 175 mm
	7018000132	Tungsten Electrode Red (Wt-20)	3.2 x 175 mm
	7018000140	Tungsten Electrode Red (Wt-20)	4.0 x 175 mm
	7018000216	Tungsten Electrode Green (Wp)	1.6 x 175 mm
	7018000220	Tungsten Electrode Green (Wp)	2.0 x 175 mm
	7018000224	Tungsten Electrode Green (Wp)	2.4 x 175 mm
	7018000232	Tungsten Electrode Green (Wp)	3.2 x 175 mm
	7018000240	Tungsten Electrode Green (Wp)	4.0 x 175 mm
	7018000316	Tungsten Electrode Grey (Wc-20)	1.6 x 175 mm
	7018000320	Tungsten Electrode Grey (Wc-20)	2.0 x 175 mm
	7018000324	Tungsten Electrode Grey (Wc-20)	2.4 x 175 mm
	7018000332	Tungsten Electrode Grey (Wc-20)	3.2 x 175 mm
	7018000340	Tungsten Electrode Grey (Wc-20)	4.0 x 175 mm

Regulators and Heaters	Product Code	Product Name
	7020001005	CO ₂ Regulator
	7020001004	Argon/Mix Regulator
	7020009002	Heater 220V
	7020009003	Heater 24V







- Standard
- Optional

Plasma Consumables

Consumables		Ampere	Usage	
			Drag Cutting	
	Electrode	30 A	7042E00002	●
	Swirl Ring	30 A	7042220478	●
	Nozzle	30 A	7042220480	●
	Shield Body (Retaining Cap)	30 A	7042220483	●
	Shield	30 A	7042220569	●

● For All Types

Plasma Consumables

Consumables		Ampere	Usage					
			Drag Cutting		Precision Cut		Gouging	
	Electrode	45-105A	7042E00001	●	7042E00001	●	7042E00001	●
	Swirl Ring	45 A	7042220857	●	7042220947	●	-	
		65 A	7042220857	●	-		7042220857	●
		85 A	7042220857	●	-		7042220857	●
		105 A	7042220994	●	-		7042220994	●
	Nozzle	45 A	7042220941	●	7042220930	●	-	
		65 A	7042220819	●	-		70422208NG	●
		85 A	7042220816	●	-		70422208NG	●
		105 A	7042220990	●	-		70422209NG	●
	Shield Body (Retaining Cap)	45-85 A	7042220854	●	7042220854	●	7042220854	●
		105 A	7042220855	●	-		7042220855	●
		45-85 A Ohmic	7042220953	●	7042220953	●	-	
		105 A Ohmic	7042220954	●	-	●	-	
	Shield	45-85 A	7042220818	●	7042220955	●	70422209SG	●
		105 A	7042220992	●	-		70422209SG	●
		45-85 A	7042220817	●	7042220948	●	-	
		105 A	7042220993	●	-		-	
	Deflector	45 A	-		7042220931	●	-	

- For All Types
- Only for Drag Cutting
- Only for Mechanized Cutting

Non-Stop Welding Since 1957

Magmaweld is a developer & manufacturer of Stick Electrodes, MIG/MAG & TIG Wires, Flux Cored Wires, Submerged-Arc Wires and Fluxes, Welding Machines, Fume Extractors, Welding Ancillary Products and Robotic Automation Systems since 1957 in Turkey. 95% of its sales program is manufactured by the two factories in Manisa/Turkey.



(+90) 444 93 53
magmaweld.com
info@magmaweld.com